

YOUR COMPETITIVE EDGE

It is our mission to create software and services that solve manufacturing challenges — with an uncompromising focus on the success of our customers. The benefits you will appreciate in Mastercam 2020 result from four strategic touchpoints for connectivity, efficiency, and advanced technology in the development of Mastercam solutions for manufacturing.

PERFORMANCE

Powerful tools for speedy performance.

Mastercam is easy and intuitive to use but maintains a depth of features to support the most complicated jobs. Our toolpaths are elegant and remarkably efficient.

PRODUCTIVITY

Advanced solutions for manufacturing.

We help connect the largest CAM community worldwide, and our success is a direct result of listening and responding to industry needs for productivity solutions from job set up to job completion.

PARTNERSHIP

Focus and cooperation for innovation.

Our dedication to the manufacturing community drives Mastercam innovation. We collaborate with leading tooling, software, and machine tool manufacturers to develop new technologies.

PROGRESS

Managing resources for better results.

Opportunities to drive down costs and increase profits can be found across the entire shop. Mastercam supports improved use of data-driven manufacturing in the digital age.



Over **430** sales and support offices worldwide



Local training, services, and technical support in **100 countries**



Most **widely used** CAD/CAM software in the world



More than **260,000** installed seats of Mastercam

MOVING FORWARD – TOGETHER

Since day one, Mastercam has experienced steady growth and expansion. Our success is a direct result of staying connected — to our partner network, to our customer base, and to the trends of the manufacturing industry. We adapt to changing needs to ensure that your customer experience is the best it can be.

I am proud to represent a brand with a reputation for being dependable. From our support network to our technology, you can rely on us to get the job done, because our products and our company are here for more than just making a profit. We work with purpose, to leave a positive impact on everything we touch.

As we look at Mastercam 2020 and beyond, we continue to find new ways to increase speed and efficiency in both setup and production. In addition, we see a growing need to collect, analyze, and use data across the entire manufacturing process. From the initial order through final part delivery, manufacturers are using data to make better decisions, reduce bottlenecks, and react more quickly to changes. Increasingly, CAM software is being called upon to facilitate this connected, data-driven manufacturing process.



New design features and programming improvements in Mastercam 2020 include more realistic simulation, chaining enhancements, and the ability to track associativity to reduce setup time and improve production efficiency. Improved validation tools help you make better, more informed decisions before a job is run. 3D tool enhancements, ongoing Accelerated Finishing innovations, and an expanded tool library are all developments to maximize productivity and grow your bottom line.

At Mastercam, we listen to stakeholders, not stockholders. More than 35 years into this journey together, we remain loyal to our community of innovators and manufacturers. From our Masters of CAM initiative, to industry collaborations, to an unparalleled global Reseller network, we are all about customer success through service, innovation, and design. Together, we are finding new and better ways of doing business. Together, we are Shaping the Future of Manufacturing™.

Meghan West
President and CEO, CNC Software, Inc.

MASTERCAM'S LATEST INNOVATIONS FROM START TO FINISHING

DYNAMIC MOTION TECHNOLOGY IS A GAME CHANGER



Dynamic Motion™ toolpaths maximize material removal rates and can reduce cycle times by 25 to 75%. Dynamic Motion uses a proprietary set of rules to continually adjust toolpath motion to maintain a constant chip thickness everywhere on the part. This results in consistent machining performance, shorter cycle times, and longer tool life.

The secret is in the chips.

A consistent chip load is crucial to an efficient cut. Mastercam's Dynamic toolpaths calculate the precise peak efficiency of the tool, material, and speed. When you get it right, heat is taken away in the chips, keeping the tool and part cool to the touch. You see it in uniform chip size. You hear it in how the machine runs. You'll appreciate it in dramatically shorter run times, fewer tool replacements, and a much stronger bottom line.

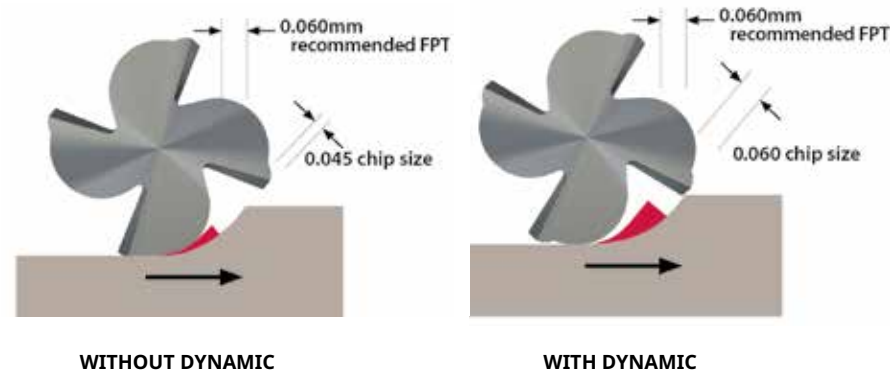

Dynamic Motion's power is derived from the recommended chip load for the tool, the optimum feed rate, and recommended surface speed.

Optimum cutting on any geometry.

Dynamic Motion maintains conditions across the entire cut by calculating optimum feed rate for a given material, tool, and tool diameter. You will see that chip size never varies. You will hear the difference, too. No chirping, squealing, or chatter. Just fast, consistent, and safe machining.

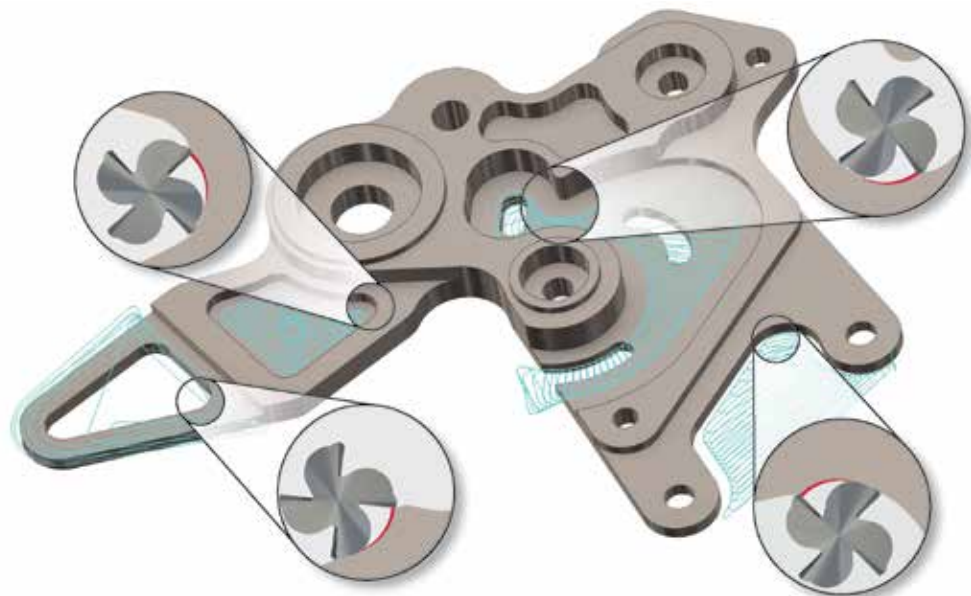

ACCELERATED FINISHING TECHNOLOGY GIVES YOU NEW WAYS TO WORK FASTER

The next leap forward in shorter cycle times.

Mastercam's Accelerated Finishing™ technology is a leap forward in addressing today's innovative profile tools and processes aimed at greater efficiency and higher machining productivity. Collaborating with the industry's smartest tool manufacturers, our software takes full advantage of these new tool designs to dramatically reduce finishing cycle times while actually improving surface finish.

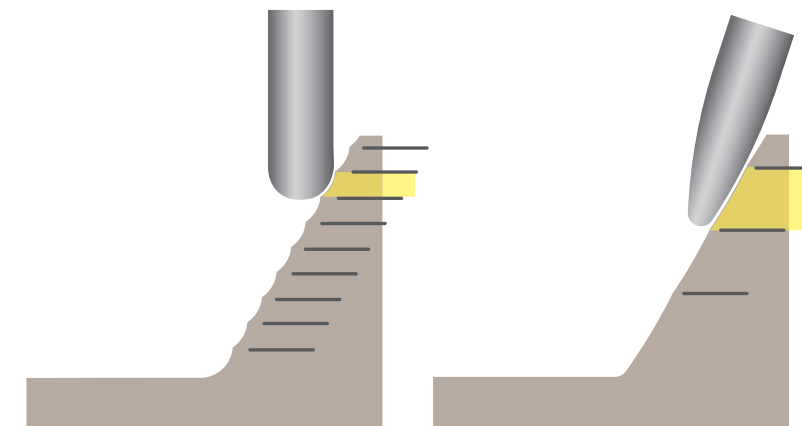

Traditional ball or bullnose endmills require many passes and leave cusps to be finished later.

Newly designed finishing tools increase contact area. This means fewer passes and shorter cycle times with equal or better surface finish.

Fewer passes. Better surface finish.

Leveraging new designs in large-radii tool profiles, Mastercam's Accelerated Finishing maximizes tool contact area. That means fewer passes, flatter cusps, and a better surface finish.

Innovations designed for your business.

Mastercam's Dynamic Motion toolpaths cut roughing times by up to 75%. And now with our exclusive Accelerated Finishing technology, total cycle times are again being dramatically reduced.

Maximum machining effectiveness is achieved at the intersection of optimal machine capability, maximum cutting tool performance, and optimized toolpath strategies. Mastercam's Dynamic Motion and Accelerated Finishing technologies provide the toolpath performance needed to reach this goal.

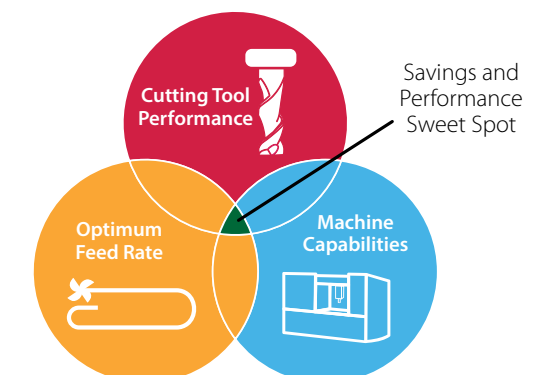

Mastercam is designed to help you consistently hit the savings and performance "sweet spot" of faster run times and less wear on machines and tools.



MILL

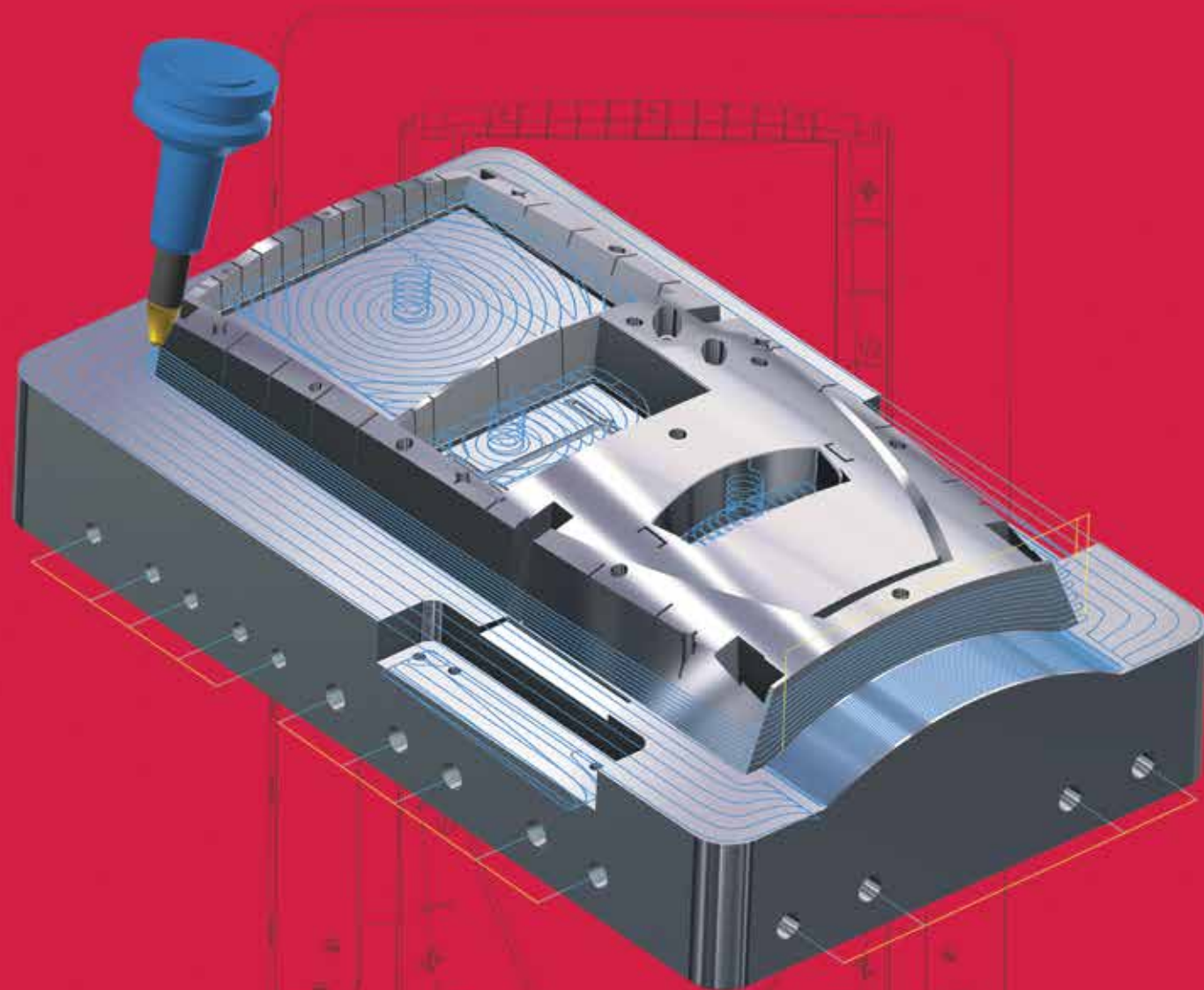

Mastercam Mill is rich in features yet still simple and intuitive to use.



Mastercam Mill includes the option to run a corresponding Mastercam for SOLIDWORKS® environment. Standalone licenses of Mastercam for SOLIDWORKS® Mill and Mill 3D are also available for purchase.

INTELLIGENT MACHINING SAVES TIME AND MONEY

Mastercam's Dynamic Motion and Accelerated Finishing combine for powerful productivity gains.

For nearly a decade, Mastercam has included Dynamic Motion. Carving out massive amounts of material quickly while dramatically extending tool life, Dynamic Motion immediately saves money. Combined with vendor-specific tool support and Mastercam's expanded Accelerated Finishing, projects come off the machine faster and with higher quality than ever before.

Mastercam Mill has been shop-tested more than any CAM program in the world. You can count on Mastercam for real-world, proven results.



TIME AND MONEY

100 steel (4140) parts cut with and without Dynamic toolpaths.

WITH

3 mins. 17 secs.
\$100/hour machine cost
3 mins. 17 secs. x \$100/hour = \$6.03
\$6.03 per part
x 100 parts = **\$603**

WITHOUT

16 mins. 41 secs.
\$100/hour machine cost
16 mins. 41 secs. x \$100/hour = \$27.81
\$27.81 per part
x 100 parts = **\$2,781**

Real world savings of 78%

Flexible, expandable, and connected.

Comprehensive toolpath strategies provide multiple approaches for programming any part, regardless of complexity. Modify any element, and toolpaths are updated, eliminating rework.

Build libraries of your favorite machining strategies. Choose customized operations, apply them to your next job, and reduce your programming time. With interfaces to digital tool libraries and other manufacturing software, Mastercam ensures you are ready for the next digital revolution. Fast, easy, productive — the way programming should be.

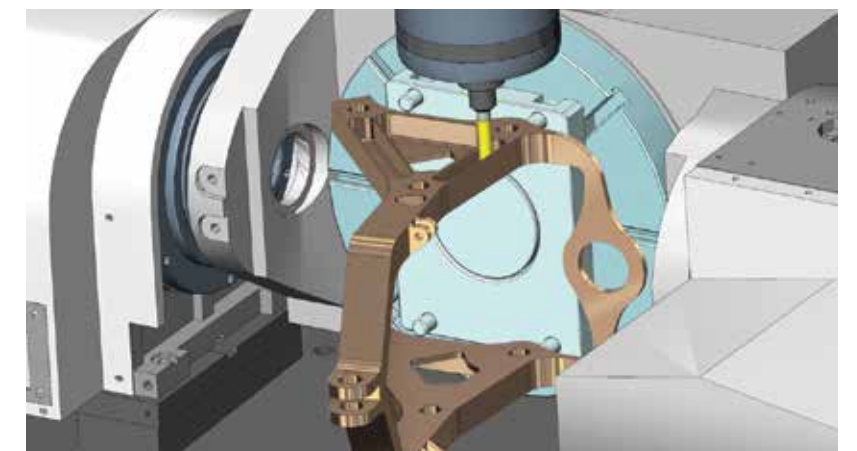

Mastercam's active Stock Model, Toolpath Verification, and Simulation mean increased confidence on every project. Tool library support, including CoroPlus® and MachiningCloud, helps you make tooling decisions fast.

2D MACHINING

Serious 2D capability.

From simple to complex, Mastercam Mill's 2D machining capability delivers the tools you need to compete.

- **Feature Based Machining (FBM)** automatically programs prismatic solid features like drill holes, contours, and pockets.
- Easy, automated, flexible hole making.
- Precision chip control for a wide set of tools, plus specialized tool support including ISCAR®'s **High Efficiency Machining (HEM)** tool set and more.

Dynamic Motion powers much of our 2D solutions. It allows you to maximize your material removal rate and can lower your cycle time, while increasing the life of your cutting tools. Check out Mastercam.com/Dynamic to learn more.

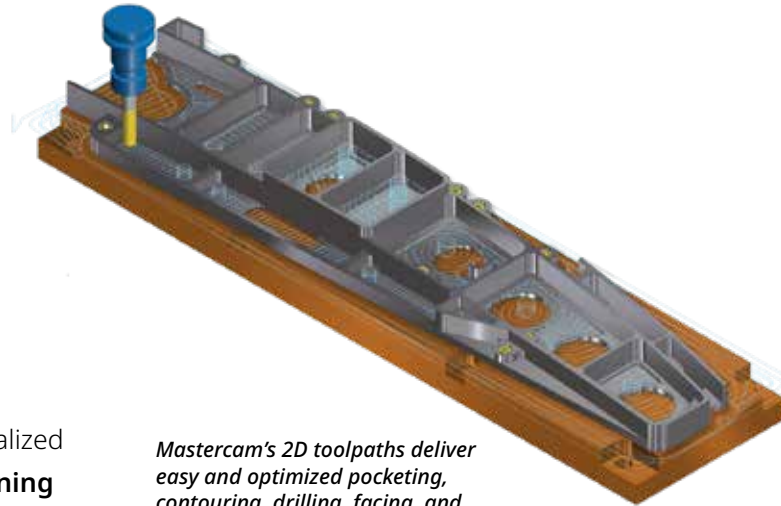

Mastercam's 2D toolpaths deliver easy and optimized pocketing, contouring, drilling, facing, and much more.



The proof of any CAM software is what comes off the machine. Mastercam is crafted to help you get the best possible finish in the shortest amount of time.

3D MACHINING

Our finish is more finished.

Mastercam provides unsurpassed control on surface cuts, delivering superior finishes and optimized cycle times.

- Mastercam's Dynamic Motion technology powers **dramatically efficient roughing**.
- Constant scallop machining maintains a consistent finish on sloped and flat surfaces.
- Constant-Z rest milling (remachining) identifies and machines areas needing a smaller tool.
- **Hybrid finishing** creates a single toolpath that changes cut methods as the slope changes.
- **Pencil tracing** walks a tool along the intersection of surfaces to clean out hard-to-reach areas.

Cut multiple surfaces, solid models, and STL data — our refined 3D toolpaths give you a smooth, precision finish to please even your toughest customers.

MULTIAXIS MACHINING

Complexity simplified.

With Mastercam, you have complete control over the three crucial elements of multiaxis machining: cut pattern, tool axis control, and collision avoidance. From 4-axis rotary and roll-die cutting to multiblade impellers with tight internal cuts, Mastercam helps simplify even the most complex jobs.

Other highlights include:

- **Multisurface 5-axis** roughing and finishing (including depth cuts), plunge roughing, and flowline machining.
- Swarf machining over multisurface floors.
- **Advanced gouge checking**, a "safe zone" around the part, and safe linking between operations .
- Fast, simple 5-axis trimming and stock-aware drilling.
- Ability to create full 5-axis motion from a **3-axis toolpath**.

For specialty machining, ask about these available Add-Ons:

- **Mastercam Blade Expert** for multibladed parts and hubs.
- **Mastercam Port Expert** for head ports and tube-type applications.

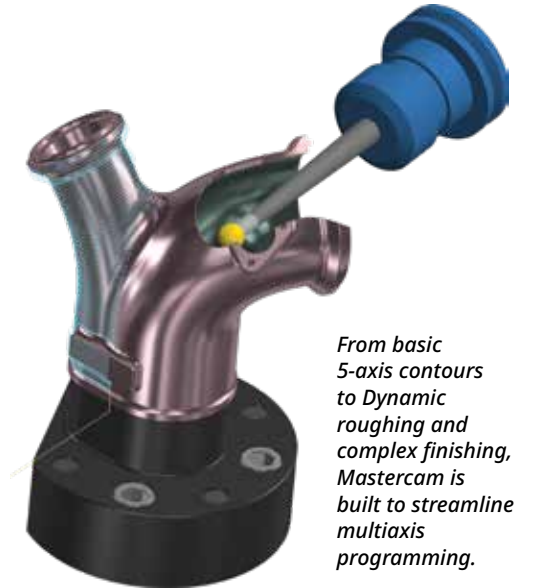

From basic 5-axis contours to Dynamic roughing and complex finishing, Mastercam is built to streamline multiaxis programming.

MASTERCAM'S SPECIALIZED ADD-ONS

Very often, that one additional CAD or CAM tool makes a specific job easier, faster, and more profitable. If you need very specialized options to precisely match your customer, your workflow, or your products, Mastercam Add-Ons can help.



Port Expert

Create precision engine cylinder head porting toolpaths on surface or solid data, while minimizing unnecessary motion.



Blade Expert

Highly efficient toolpaths for multibladed parts, delivering superior blades, splitters, floors, and fillets.



ProDrill

Automatically detect, group, and apply drill strategies to large amounts of holes, and automatically create tool definitions from existing geometry.



5-Axis Swarf Cutting

One of the more popular multiaxis techniques, 5-axis swarf machining expands the types of jobs you can do; can be upgraded to the full Multiaxis product.



5-Axis Curve Machining and Drilling

Two targeted, powerful, multiaxis techniques that add extra flexibility to your milling; can be upgraded to the full Multiaxis product.



Mastercam Productivity+™

Brings Renishaw® in-process probing and inspection to your Mastercam programs. Easily set up, validate, and even make in-process adjustments where appropriate.



Art

Quickly bring your 2D sketches, clip art, photos, and CAD files to life by crafting them on-screen and cutting them with easy, specialized toolpaths.



LATHE

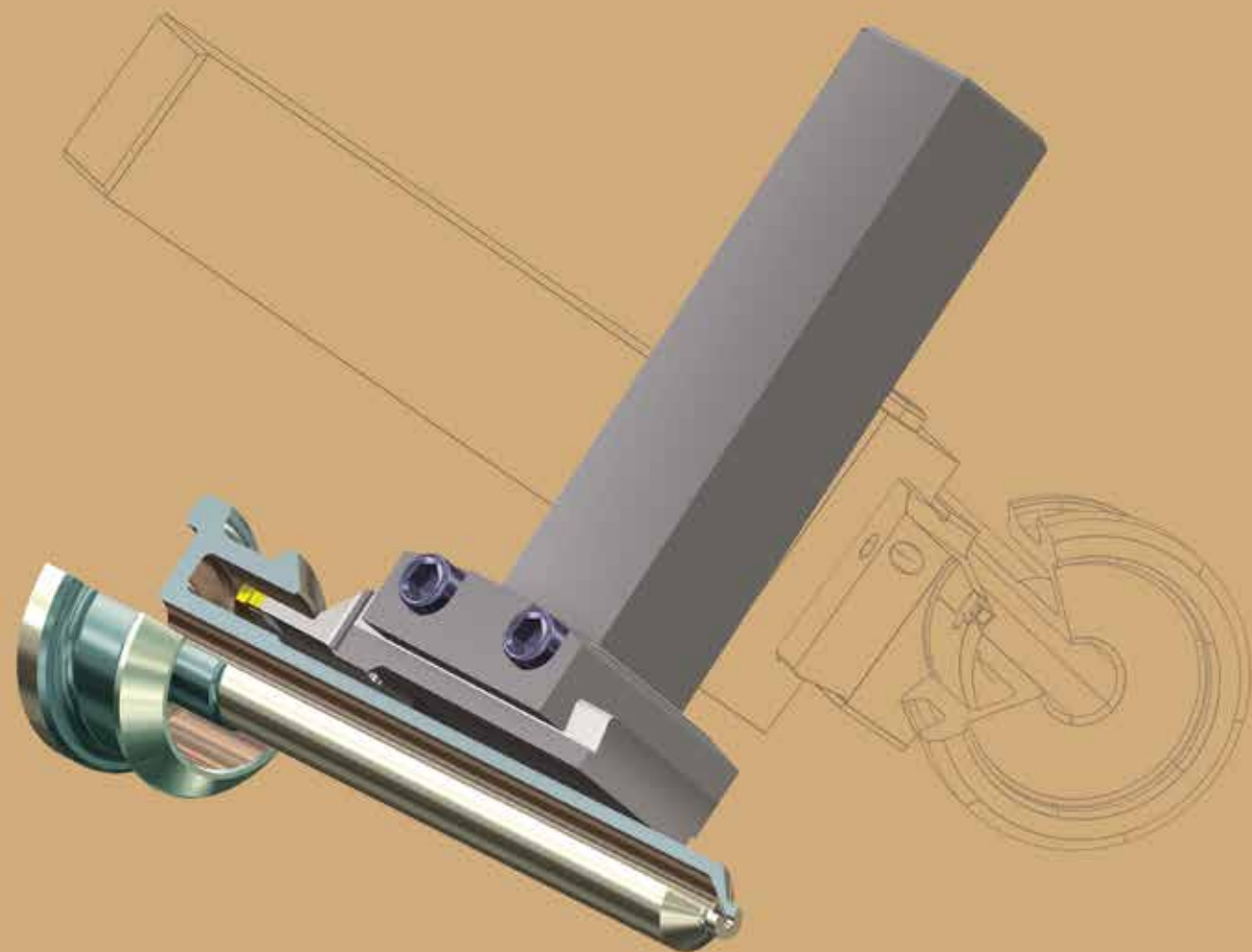

Mastercam Lathe lets you move the same part file between milling and turning operations with ease and confidence.



Mastercam Lathe includes the option to run a corresponding Mastercam for SOLIDWORKS® environment. Standalone licenses of Mastercam for SOLIDWORKS® Lathe are also available for purchase.

POWERFUL, FLEXIBLE TOOLS FOR TURNING

A set of tools that streamlines your entire process.

From importing CAD files to Dynamic roughing and precision finishing, Mastercam Lathe gives you a variety of strategies to turn parts with greater efficiency and productivity.

Efficient programming, designed for modern manufacturing.

Mastercam Lathe delivers a set of easy-to-use, advanced programming tools, with greatly expanded options when paired with Mastercam Mill. Easy rough, finish, thread, groove, bore, and drill routines combine with C/Y-axis machining to cut any job. Dependable toolpath verification ensures your parts are done right the first time.

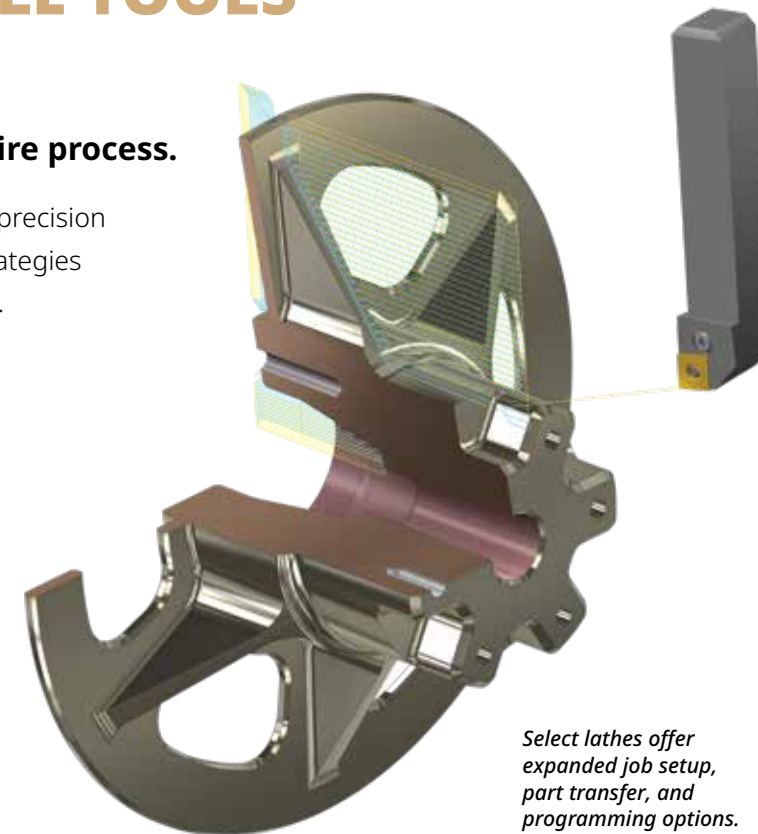

Select lathes offer expanded job setup, part transfer, and programming options.

TIME AND MONEY

100 Hastelloy parts cut with and without Dynamic toolpaths.

WITH	WITHOUT
40 minutes	5 hours
1.5 inserts per part	12.5 inserts per part
40 mins. x \$100/hour = \$66	5 hours x \$100/hour = \$500
1.5 inserts @ \$25 = \$37.50	12.5 inserts @ \$25 = \$312.50
\$103.50 per part x 100 parts = \$10,350	\$812.50 per part x 100 parts = \$81,250

Real world savings of 87%

Important turning features.

- **Quick Toolpaths** let you program in a few clicks.
- Intelligent ID and OD roughing.
- **Dynamic Motion** roughing extends insert life.
- Rough parts in sections or over the entire model.
- Fast facing including roughing and finishing.
- Grooving with multiple depth cuts, including peck motion and full-radius plunge turning.
- Complete and easy threading.
- Control chip breakage on difficult-to-machine materials.
- **Automatic gouge checking** on the tool's front and back.
- Chuck, part, steady rest, and tailstock detection.
- Easily machine wireframe, surface, and solid models.
- Create turning profiles on any shaped part.
- **Full milling support available** for machines with live tooling for C and Y axes.
- Expanded job setup, part transfer, and programming options on select lathes.



MILL-TURN

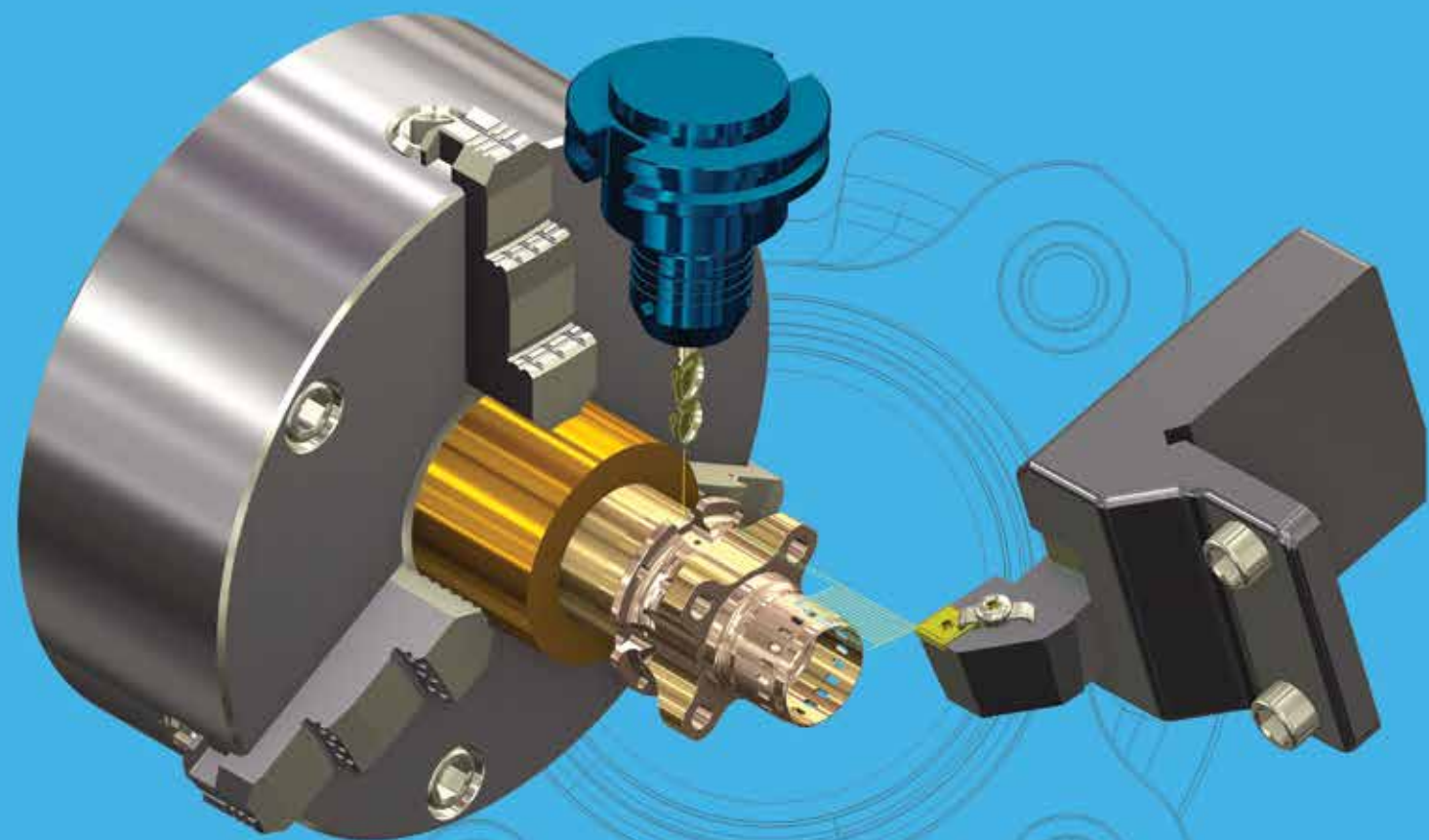

Automate your complex programs on today's high-powered, multitasking machining centers. Program it right the first time, every time.

SIMPLIFY COMPLEX MACHINING

Mastercam Mill-Turn simplifies today's high-powered, multistream machining centers.

With Mastercam, your workflow is efficient. Choose your machine, and Mastercam Mill-Turn automates part transfers, tool planes, stock definition, and setup. Then apply your toolpaths, quickly synchronize them, verify your project with simulation, and post your code. Changes along the way are fast and easy — the way programming should be.

Mill-Turn's Sync Manager is a user-friendly way to optimize part cycle times and manage interactions between toolpath operations. Easily navigate our Gantt-style timeline and vertical stream interface to coordinate operations and track cycle times.

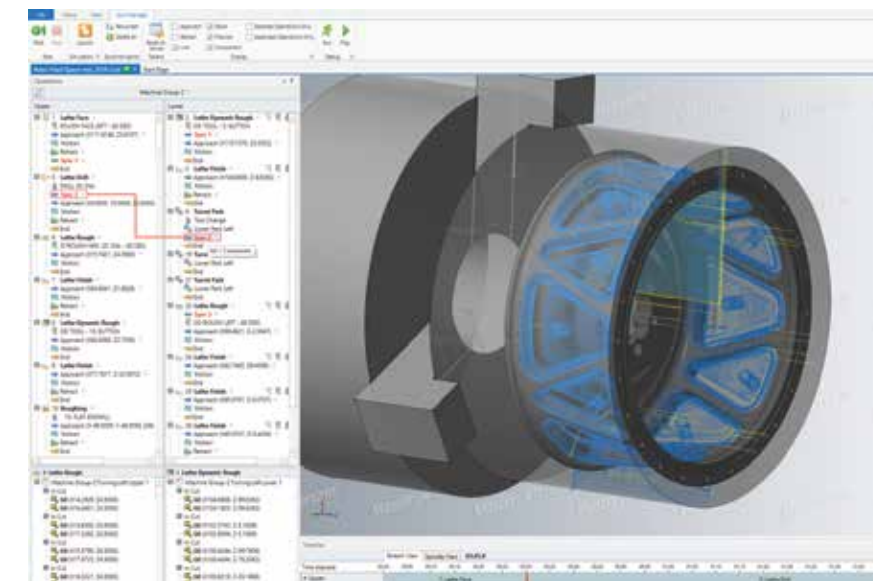

Fast, flexible setup, synchronization, and simulation combine to help you get the most out of your mill-turn machines.

Get more out of your machines with Machine Simulation.

Machine Simulation provides visual verification and assurance that the interaction and syncing between operations performs exactly as you planned. Validate against potential collisions and track cycle time estimates to achieve maximum efficiency.

Avoid mistakes. Save time and money.

All machine components, workholding, stock, tools, and parts are simulated from the safety of your desktop, ensuring a safe and secure machining experience. You can identify potential collisions, see your cutting motion, and explore ways to optimize your processes with simulation. View all streams and statistics of the entire machining process with the capability to jump to any point in the process with the click of a button.

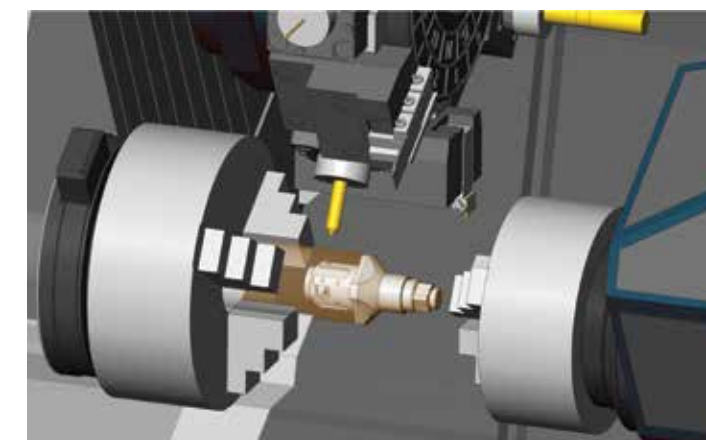

Get the most from your machine with multistation and half-index tool support.

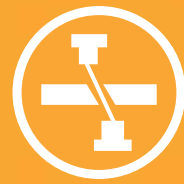

WIRE

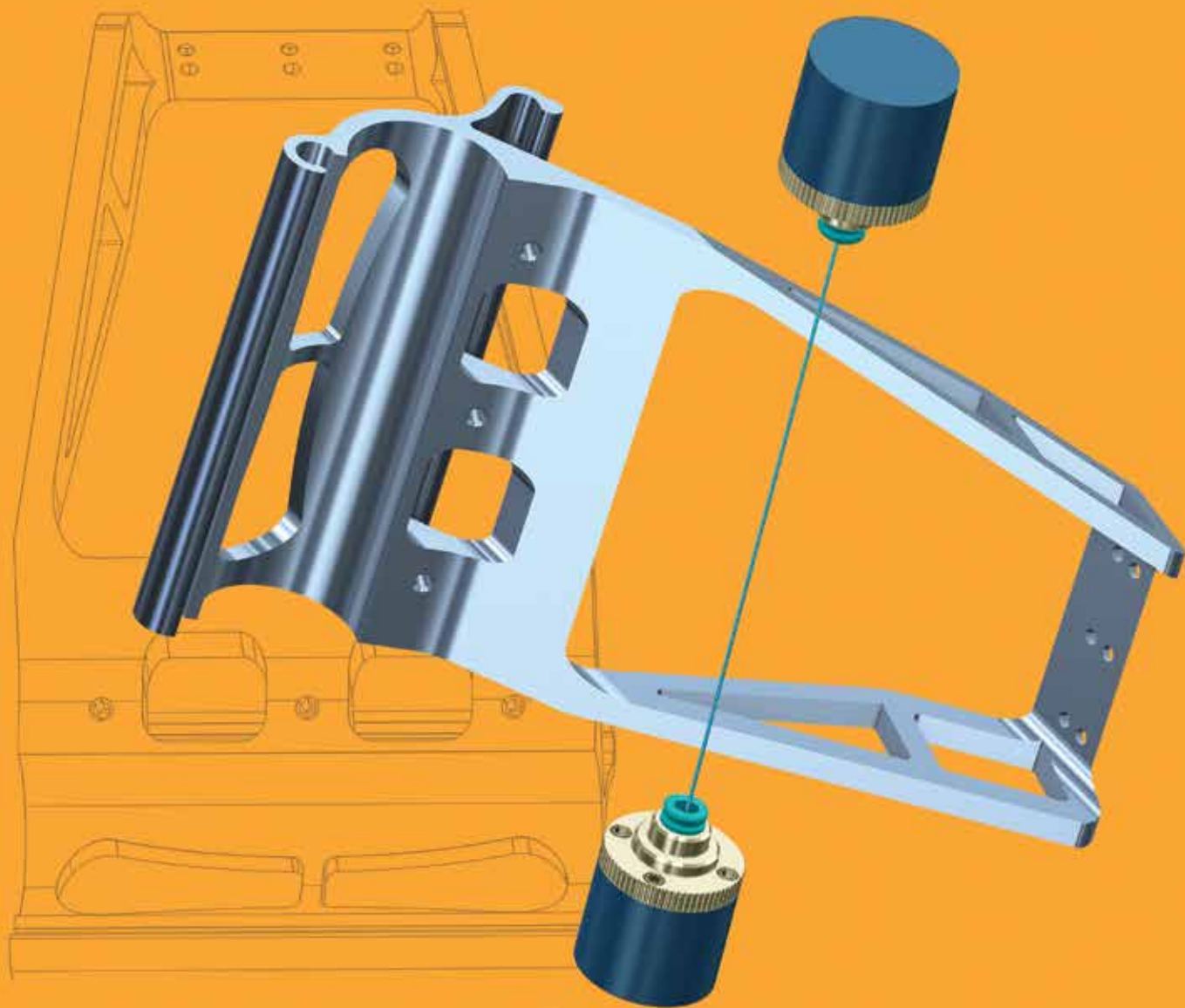

Mastercam Wire delivers powerful, comprehensive wirepaths in a streamlined, easy-to-use interface.

THE MASTERCAM DIFFERENCE

Designed for efficiency.

Mastercam Wire lets you move a single part file between machines, saving time and avoiding mistakes. User-customizable wire libraries store power settings and other registers for rough and skim passes.

Other features include:

- Efficient tab creation and management.
- Control settings for corner types and taper angles at any point in the contour.
- Straight or tapered cut from either direction.

From 2- and 4-axis cutting to easy syncing and complete tab control, Mastercam Wire delivers tools for fast, efficient wire programming.

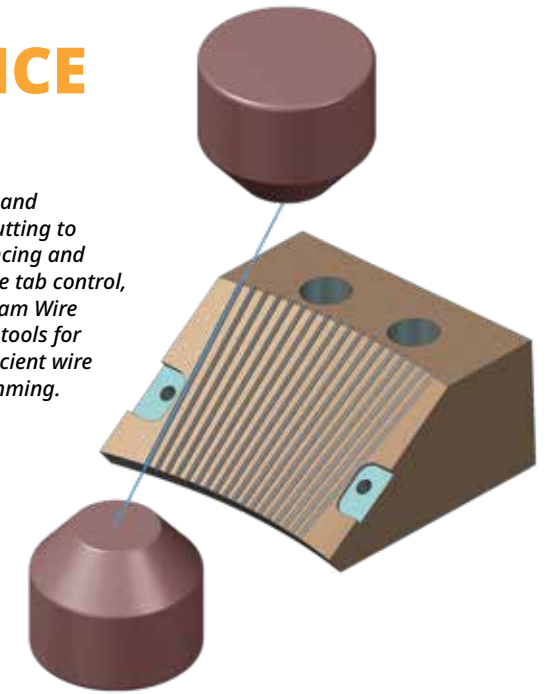

Having the best software is only one of many ingredients for success.

A global community of Mastercam users, experts, educators, and enthusiasts helps you get the most from your investment. Mastercam Resellers bring years of experience, helping to ensure that you are getting the most practical and comprehensive support in the industry.

Machine support for Mitsubishi, Sodick, Makino, AgieCharmilles, and many others.

Expand your shop's capabilities.

For basic 2-axis contouring and complex 4-axis motion, Mastercam ensures that you are ready for any job. Mastercam delivers:

- **Contouring** made easy in 2- or 4-axis.
- **Automatic** lead-in and lead-out strategies.
- **Automatic or manual** 4-axis syncing.
- **Automatic** skim and reverse cuts.

Open virtually any CAD file or use Mastercam's built-in 3D modeling tools.

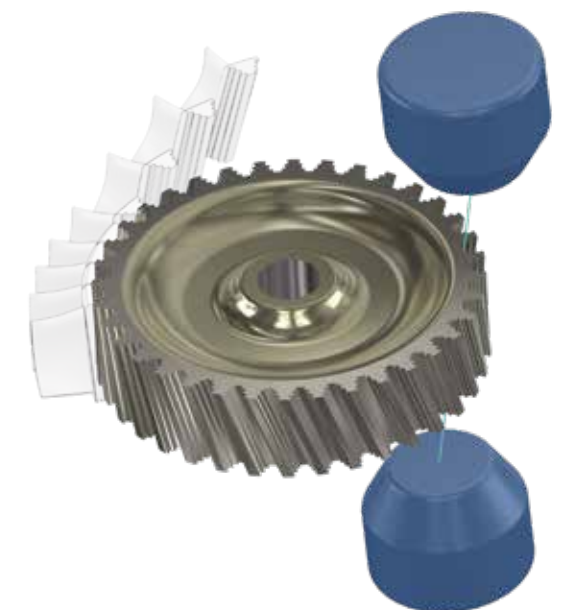



ROUTER



Mastercam Router brings complex routing functionality with an easy-to-use interface.



Mastercam Router and Router 3D include the option to run a corresponding Mastercam for SOLIDWORKS® environment.

FLEXIBLE AND EXPANDABLE

Mastercam Router offers solutions for all your 2D, 3D, or multiaxis challenges — from wood to composites.

Once you program a part, no matter how complex, you can modify any element of the job and immediately get updated toolpaths without slowing down. You can also build a library of your favorite machining strategies and apply them to new models.

Mastercam's powerful Dynamic Motion technology not only helps extend tool life and reduce machine wear, but helps eliminate tool dwell damage as well. **Automatic Toolpathing (ATP)** brings in parts from today's top design packages to help speed flat panel work.

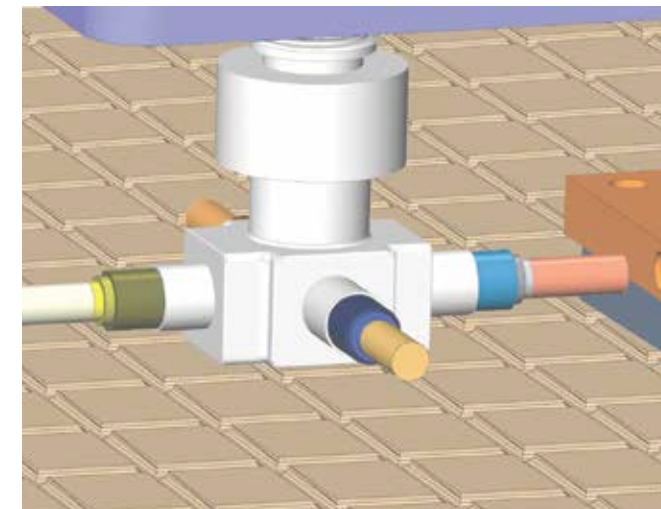

Mastercam Router streamlines multiple tool programming including block drills and aggregate heads.



Part and toolpath nesting increase project yields and profitability.

A comprehensive package of powerful tools.

2D machining can range from simple to very complex. Mastercam Router delivers powerful 2D tools from contouring, pocketing, and drilling to automated, feature-based, solid model programming.

For 3D machining, Mastercam Router gives you streamlined, efficient 3D roughing and finishing, including automated leftover stock cleanup.

Mastercam's multiaxis capabilities give you complete control over the three crucial elements of multiaxis machining: cut pattern, tool axis control, and collision avoidance.



MASTERCAM for SOLIDWORKS®

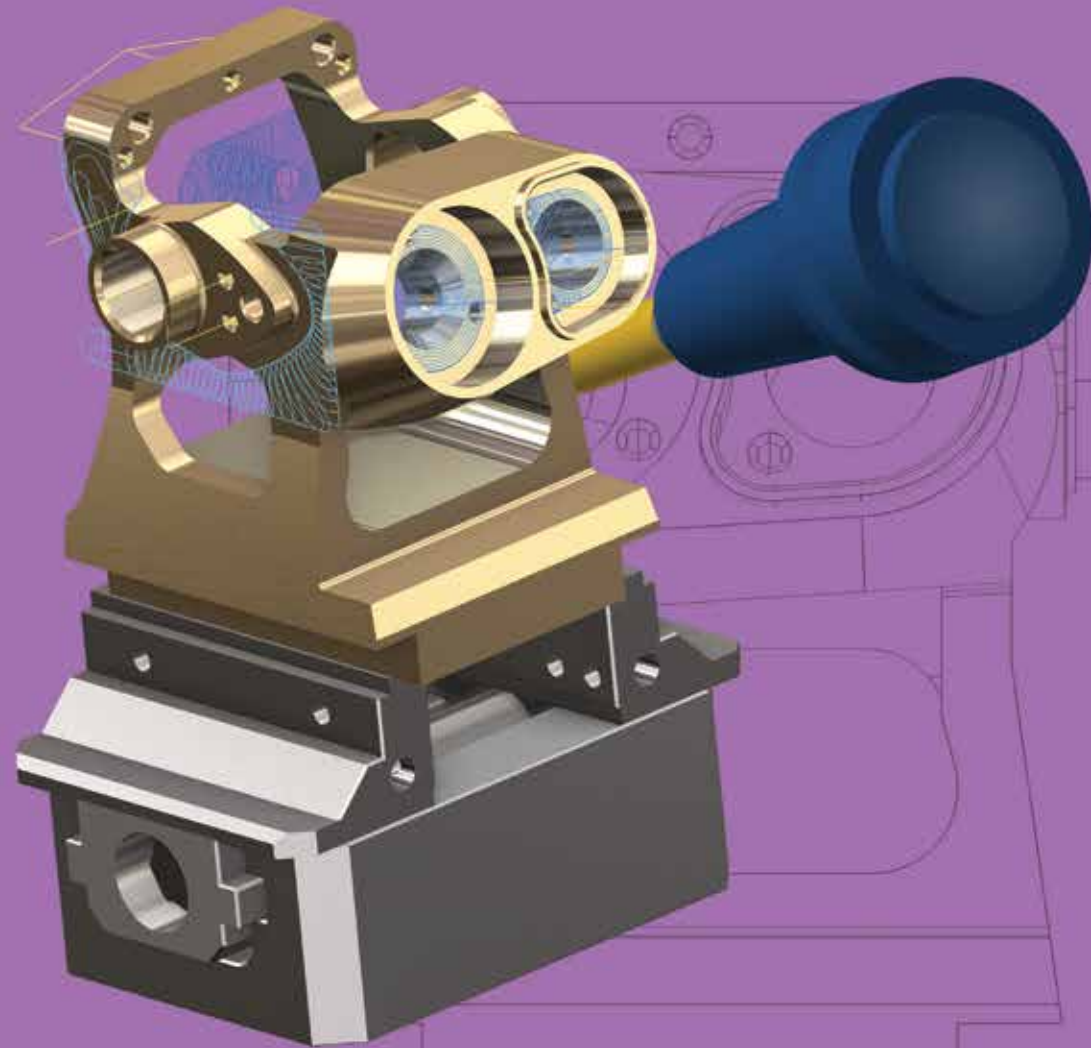

Mastercam for SOLIDWORKS® combines the world's leading modeling software with the world's most widely used CAM software.



Mastercam Mill, Mill 3D, Lathe, Router, and Router 3D include the option to run a corresponding Mastercam for SOLIDWORKS® environment. Standalone licenses of Mastercam for SOLIDWORKS® Mill, Mill 3D, and Lathe products are also available for purchase.

SOLIDWORKS USERS FEEL AT EASE WITH MASTERCAM

Mastercam for SOLIDWORKS combines the world's leading modeling software with the world's most widely used CAM software.



With Mastercam toolpaths integrated directly within the SOLIDWORKS environment, the toolpaths are applied directly to the part or assembly. Intelligent use of design tables and multiple configurations makes working with families of parts easy.

As a Certified Gold Product, Mastercam for SOLIDWORKS delivers the absolute best in 2- through 5-axis milling, routing, and turning CAD/CAM integration.

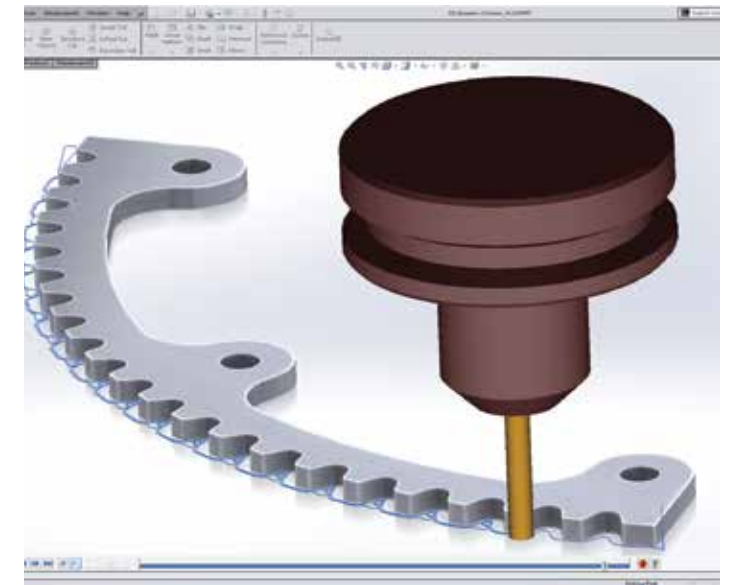

TIME AND MONEY

100 steel (4140) parts cut with and without Dynamic toolpaths.

WITH

3 mins. 17 secs.
\$100/hour machine cost
3 mins. 17 secs. x \$100/hour = \$6.03
\$6.03 per part
x 100 parts = **\$603**

WITHOUT

16 mins. 41 secs.
\$100/hour machine cost
16 mins. 41 secs. x \$100/hour = \$27.81
\$27.81 per part
x 100 parts = **\$2,781**

Real world savings of 78%

Flexible and expandable.

No matter how complex a part, with toolpath associativity, any modification to the job means the toolpaths are updated immediately. You can also build a library of your favorite machining strategies, apply them to a part, and Mastercam helps adapt them to the new model. Because Mastercam for SOLIDWORKS is a fully integrated SOLIDWORKS Certified Gold Product, it's fast, easy, and productive — the way programming should be.

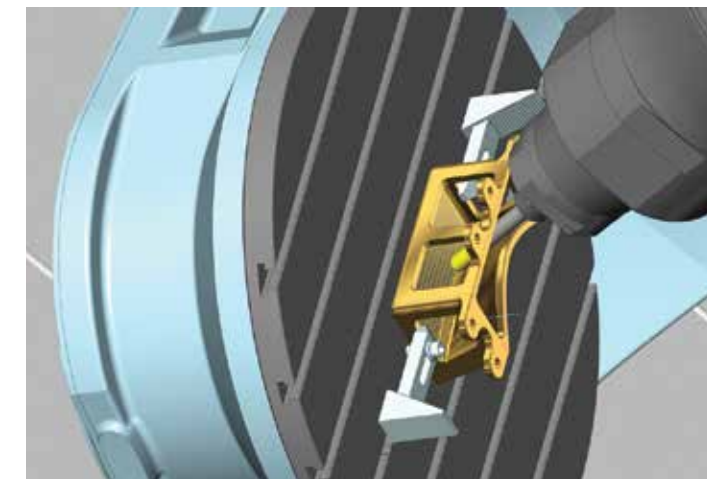

Mastercam's active Stock Model, Toolpath Verification, and Simulation mean increased confidence on every project. Tool library support, including CoroPlus® and MachiningCloud, helps you make tooling decisions fast.

2D MACHINING

Serious 2D capability.

Your daily needs for 2D machining can range from simple to very complex. Mastercam for SOLIDWORKS delivers the tools you need.

- **Feature Based Machining (FBM)** automatically programs prismatic solid features like drill holes, contours, and pockets.
- **Remachining** uses smaller tools to automatically clean out material left from previous operations.

Dynamic Motion powers much of our 2D solutions. It allows you to maximize your material removal rate and can lower your cycle time, while increasing the life of your cutting tools. Check out Mastercam.com/Dynamic to learn more.

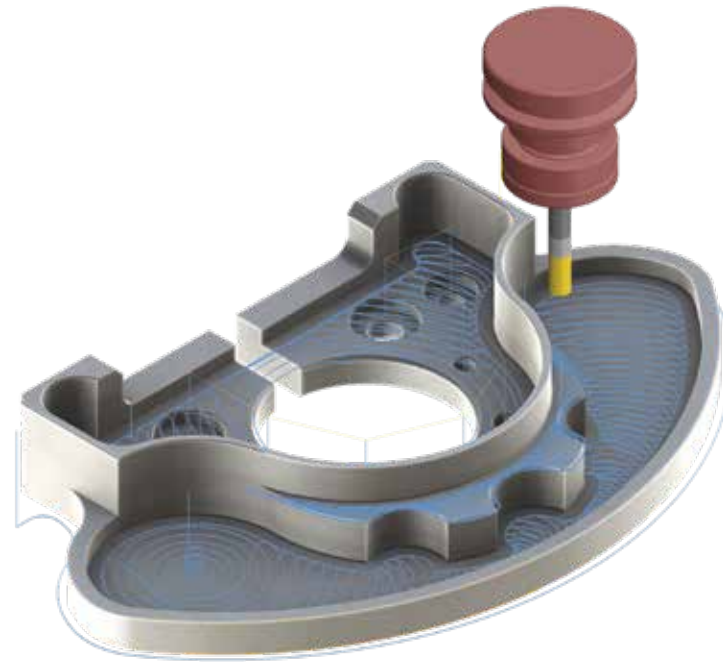

2D toolpaths in Mastercam for SOLIDWORKS deliver easy and optimized pocketing, contouring, drilling, facing, and more.

3D MACHINING

Our finish is more finished.

Mastercam delivers superior finishes and optimized cycle times. Our smart, hybrid finishing creates a single toolpath that changes cut methods as the slope of the model changes. Our refined 3D toolpaths give you the smooth, precision finish to please even your toughest customers.

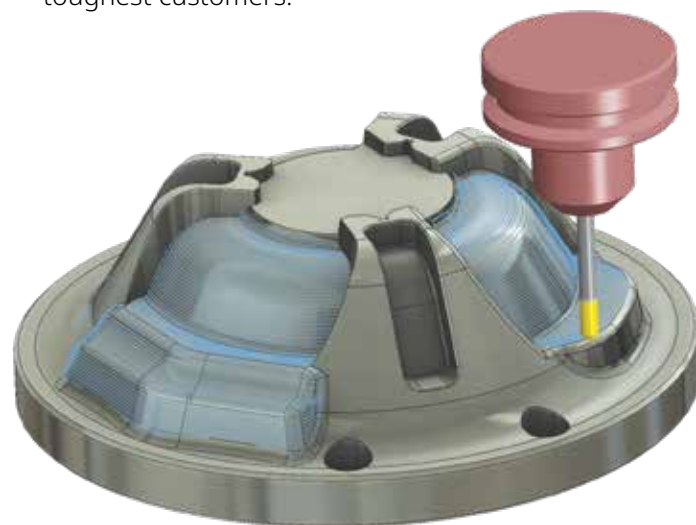

From the smallest medical part to the largest automotive mold, Mastercam for SOLIDWORKS ensures efficient roughing and precision finishing for any product.

- **Dramatically efficient roughing** powered by Mastercam's Dynamic Motion technology.
- Equal Scallop strategy provides superior surface finish and smooth machine motion.
- Constant-Z rest milling (remachining) identifies and machines areas that need to be cut with a smaller tool.
- **Hybrid finishing** creates a single toolpath that changes cut methods as the slope of the model changes.
- **Pencil tracing** walks a tool along intersections to clean out hard-to-reach areas, such as internal fillets.

TIME AND MONEY

"Mastercam for SOLIDWORKS is making my job easier. I've been using Dynamic toolpaths to get better finishes. It works so well that I'm getting work done in half the time."

Nolan Farmer, Owner
Farmer Plastics & Machining, Inc., Jamestown, CO

MULTIAXIS MACHINING

Complexity simplified.

Mastercam for SOLIDWORKS gives you streamlined control over the three crucial elements of multi-axis machining: cut pattern, tool axis control, and collision avoidance. From 4-axis rotary and roll die cutting to multiblade impellers with tight internal cuts, Mastercam helps simplify even the most complex jobs.

Other highlights include:

- **Multisurface 5-axis** roughing and finishing (including depth cuts), plunge roughing, and flowline machining.
- Swarf machining over multisurface floors.
- **Advanced gouge checking** and safe tool motion around the work piece.
- Fast, simple 5-axis trimming and stock-aware drilling.
- Easy creation of complex, 5-axis motion from simple, 3-axis toolpaths.

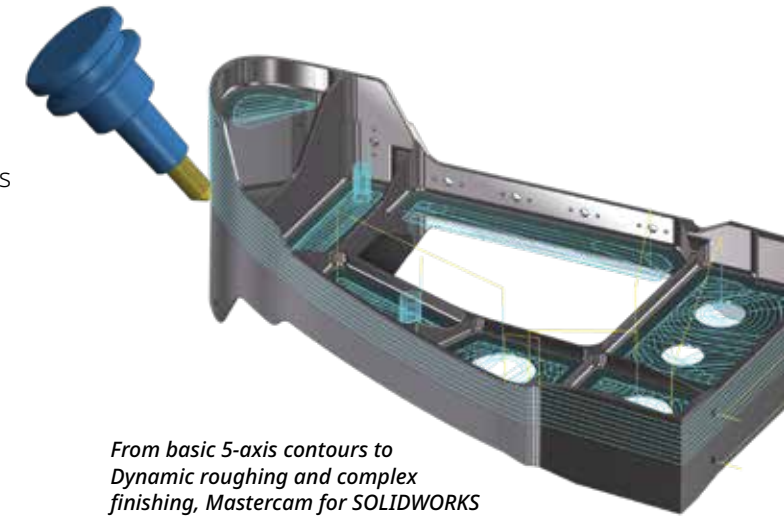

From basic 5-axis contours to dynamic roughing and complex finishing, Mastercam for SOLIDWORKS streamlines multi-axis programming by design.

TURNING

Fully integrated within SOLIDWORKS.

Powerful turning strategies in Mastercam for SOLIDWORKS complement our milling toolpaths, giving you a complete turning toolkit. Functionality includes:



- Easy roughing, finishing, threading, grooving, boring, drilling, and cut off.
- Face and cross contouring and drilling.
- Intelligent ID and OD roughing, including roughing to a boundary for castings.
- **Dynamic Motion** roughing to extend insert life.
- Tool Inspection to check tool wear conditions during your roughing, finishing, and grooving operations.
- Toolpath verification to ensure your parts are machined as intended.



DESIGN

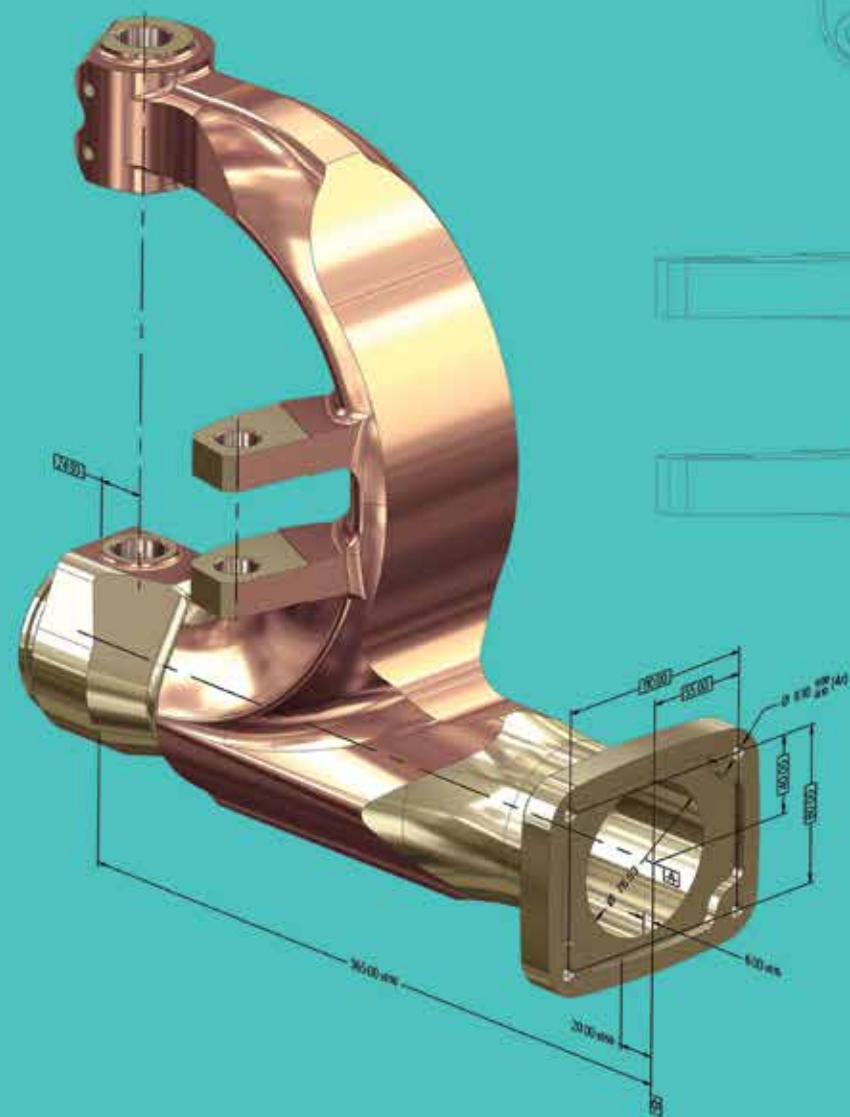

Streamlined CAD makes design work easier than ever.

MODELING AND PREP TOOLS GET YOUR PARTS ON AND OFF THE MACHINE QUICKLY

Whether you're bringing in a file from an outside CAD package or designing one yourself, Mastercam's powerful CAD engine gives you control over the final details of even the most complex jobs.

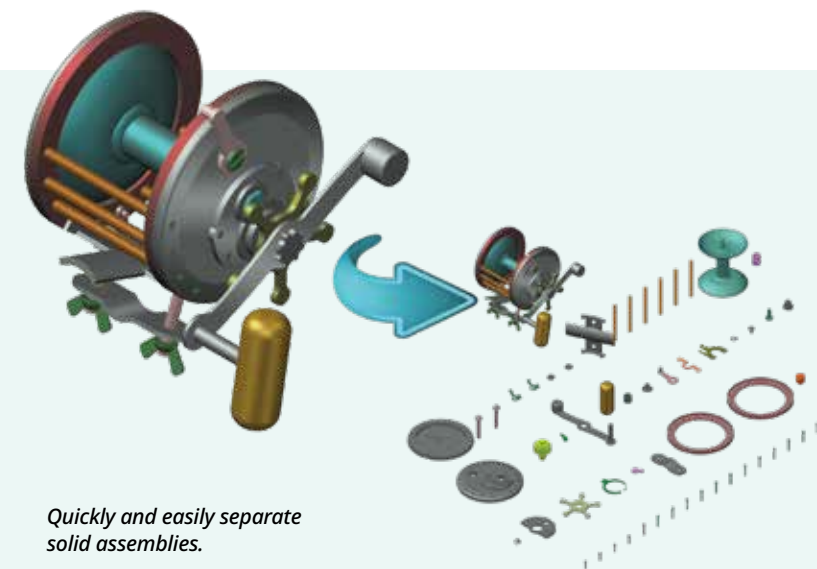

Quickly and easily separate solid assemblies.

Work with your existing CAD files.

Mastercam helps to preserve design intent with Model Based Definition (MBD) support and acceptance of varied file formats. These include IGES, Parasolid®, SAT (ACIS solids), AutoCAD® (DXF, DWG, and Inventor™ files), SOLIDWORKS® (including history tree), Solid Edge®, SpaceClaim, STEP, STL, and more. Add-On translators are available for Siemens NX, CATIA™, Pro/E (PTC Creo), and more.

Whether you are prepping customer files...

Getting a part file from an outside source can pose unique challenges. You might need to repair a surface, work with a mesh, cap or hide a feature, create an electrode, or just make sure your fixtures are represented on the part. Mastercam includes a powerful set of model prep tools to make sure the process goes smoothly. From robust surface creation and editing to "push-pull" solid model editing, Mastercam gives you the tools to bring a part from the designer's desk to your machining process, fast.

...or designing your part from scratch.

Having powerful CAD at your fingertips makes your CAM system that much more effective. Mastercam includes a robust set of modeling tools, from complete wireframe and surface modeling to solid modeling. A true hybrid modeling system, Mastercam lets you create, combine, and machine whichever CAD geometry suits your needs.

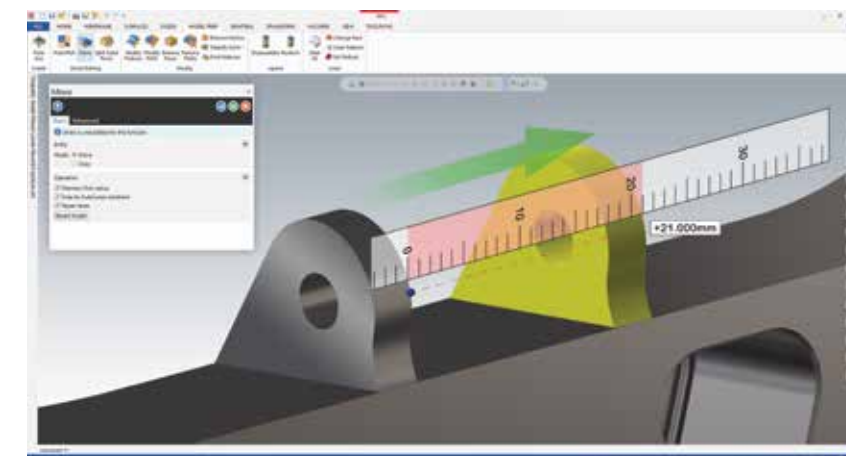

Push, pull, remove, and directly edit features on new or imported solids, even if they have no history.

MAINTAIN YOUR COMPETITIVE EDGE



The Mastercam Maintenance Advantage

Mastercam users appreciate the value that top-of-the-line CAD/CAM delivers. Now you can enhance that value by making sure your Mastercam software is always up-to-the-minute, and your shop always has the latest tools to keep you ahead of the competition.

Plus, purchasing updates is no longer a budgetary variable. Our Maintenance Program allows you to plan ahead and budget expenditure on an annual basis. New software is available to you immediately upon release, so you don't have to wait until your next budget is approved to gain the benefits of the latest productivity enhancements in Mastercam.

Key Features

- Maintenance customers receive prioritized technical support.
- Major releases are made available to customers with active Maintenance at no additional charge.
- New software and updates are delivered to Maintenance customers first.
- Maintenance customers have early access to brand new features that are pre-released before the next major release.
- Maintenance customers can participate in Mastercam Beta testing.
- Special features on Mastercam.com are made available to Maintenance customers only, including the Mastercam Tech Exchange.



CONNECTED CAM FOR A CONNECTED WORLD

Depending on whom you talk to, Industry 4.0 is either coming or already here. But there is little debate that harnessing data is the next step forward. Manufacturers around the world are using data to make faster, better decisions, reduce bottlenecks, and solve problems.

Mastercam is helping to lead the way with an open platform and premier partnerships creating new synergies among everything from paperless workflow and reverse engineering to digital tool management and robotics. These insights — plus the world's largest network of CAM support — provide the fuel you need to increase connectivity to increase productivity.

SHAPING THE FUTURE OF MANUFACTURING



Our commitment to the needs of industry includes support for educators and numerous efforts to attract students to careers in manufacturing. Our Educational Suite is supported by a wide variety of curriculum and resources for educators.

We also sponsor several programs and competitions to expand opportunities in education for students to build skills and get excited about manufacturing technology.

As the most widely used CAM software in education and industry, Mastercam is dedicated to helping future generations of machinists gain the skills and experiences needed for professional success. From the classroom to the production line, our training and support are second to none.

TOOLS TO KEEP YOURSELF COMPETITIVE



Mastercam University™

Online, video-based training developed by CNC Software, Inc. and trusted partners. Sharpen your skills on your own schedule, use it to bolster your resume, and get started on the path to Mastercam Certification — with the same training used by corporate staffers and Mastercam Resellers. Mastercam University is easy to use, gives you real-world training applications, and covers all levels of Mastercam skills from basic to advanced.

University.Mastercam.com



Mastercam Training and Support

CAD/CAM is support-intensive business. We understand that our users require comprehensive training options to get started with Mastercam and then to stay current with the latest advancements.

To get the best training, you need flexible options, and the strength of the Mastercam community means our users have access to a global network of excellent opportunities for training.

Corporate Training:

- Mastercam University offers online training courses with video-based instruction in a variety of CAD/CAM disciplines.
- In-house training events are also held at CNC Software, Inc. headquarters throughout the year. These are listed on the corporate events calendar on Mastercam.com.
- PDF tutorials and the Mastercam Knowledge Base are accessible via Mastercam.com.



Mastercam Reseller Training:

- Your local Reseller is the best source of training opportunities in your area. More than 115 Resellers in 100 countries offer Mastercam training.

Third-Party Training:

- As the most widely used CAM software, Mastercam is supported by a multitude of training options available from official Mastercam training partners.



Mastercam Certification

If you are looking to set yourself apart as a skilled Mastercam programmer in the increasingly competitive job market, Mastercam Certification is the answer. Our Mastercam Associate Level Certification is acquired by achieving scores of 80% or more in select Mastercam University courses, and our Mastercam Professional Level Certification is a proctored test administered by a Certified Mastercam Instructor. Both will give you the competitive advantage you seek.



WE SHAPE THE FUTURE.

Do you have what it takes? Tell your story at MastersofCAM.com.

For more information,
contact a local Mastercam expert at
Mastercam.com/Resellers

About Us

CNC Software, Inc. provides state-of-the-art software tools for CAD/CAM manufacturing markets. Our single focus is to provide superior software products based on our users' needs to solve simple to complex design and machining problems.

CNC Software, Inc.
671 Old Post Road
Tolland, CT 06084



www.mastercam.com

Mastercam[®]

Mastercam[®] is a registered trademark of CNC Software, Inc. SOLIDWORKS is a registered trademark of Dassault Systèmes Solidworks Corp. All other trademarks are property of their respective owners. ©1982-2019. All rights reserved.